

# T Series Crystal



- 3.2mm X 2.5mm SMD
- Wide Frequency Range
- RoHS Compliant
- Tight Tolerance and Stability



Frequency Range	12.000MHz to 54.000MHz
Frequency Tolerance / Stability	(See Part Number Guide for Options)
Operating Temperature Range	(See Part Number Guide for Options)
Storage Temperature	-40°C to +85°C
Aging	±5ppm / first year max
Shunt Capacitance	5pF Max
Load Capacitance	(See Part Number Guide for Options)
Equivalent Series Resistance (ESR)	See ESR Chart
Drive Level	10µW Typ / 100µW Max
Insulation Resistance	500 Megaohms Min at 100VDC ±15VDC

## ESR Chart

Frequency Range	ESR (Ohms)	Mode / Cut
12.000MHz to 19.999MHz	100 Max	Fund / AT
20.000MHz to 29.999MHz	80 Max	Fund / AT
30.000MHz to 54.000MHz	50 Max	Fund / AT

## Environmental & Mechanical Detail

Shock	MIL-STD-883, Method 2002 Cond B
Solderability	MIL-STD-883, Method 2003
Solvent Resistance	MIL-STD-202, Method 215
Vibration	MIL-STD-883, Method 2007, Cond A
Gross Leak Test	MIL-STD-883, Method 1014, Cond C
Fine Leak Test	MIL-STD-883, Method 1014, Cond A2
MSL	Level 1 per IPC/JEDEC J-STD 20

## Marking Detail

First Line = MXX.X (not to exceed 5 characters)		
M	=	MMD
XX.X	=	Device Frequency (four digits including decimal point)
Second Line = SYWW (not to exceed 5 characters)		
S	=	Internal Code
YYWW	=	Date Code (Year/Week)



**MMD Monitor/Quartztek**  
 30400 Esperanza, Rancho Santa Margarita, CA, 92688  
 Phone: (949) 709-5075, Fax: (949) 709-3536, [www.mmdcomp.com](http://www.mmdcomp.com)  
 Sales@mmdcomp.com



Revision: 04/19/11 H

## Part Number Guide

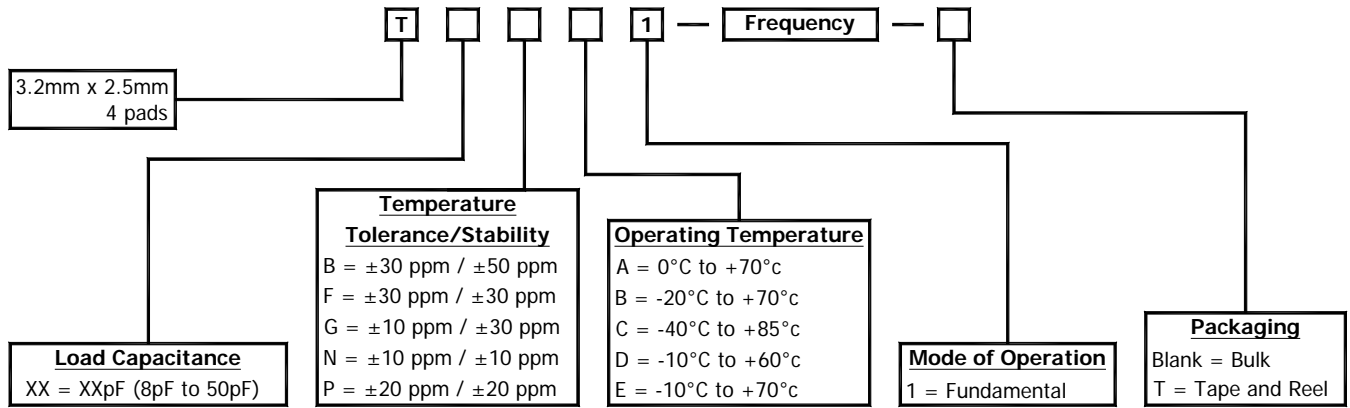

Please Consult with MMD Sales Department for any other Parameters or Options

## Mechanical Details

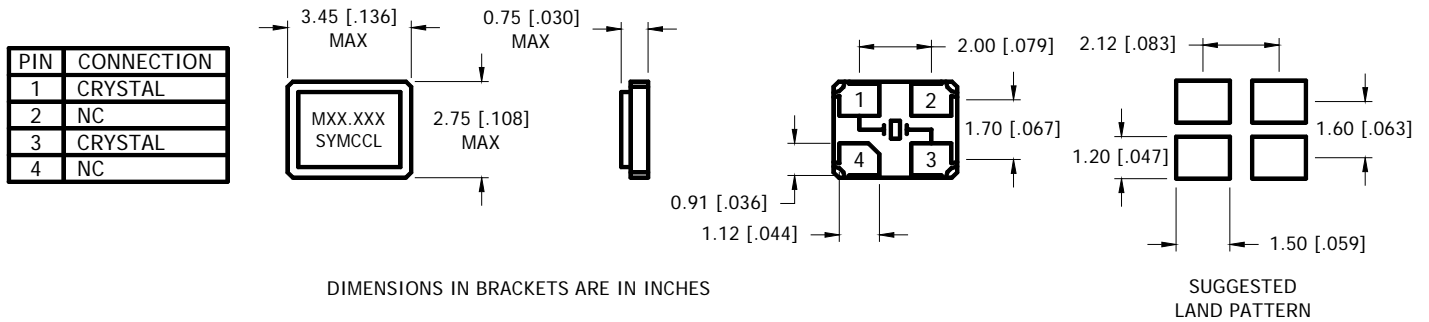

## Tape and Reel

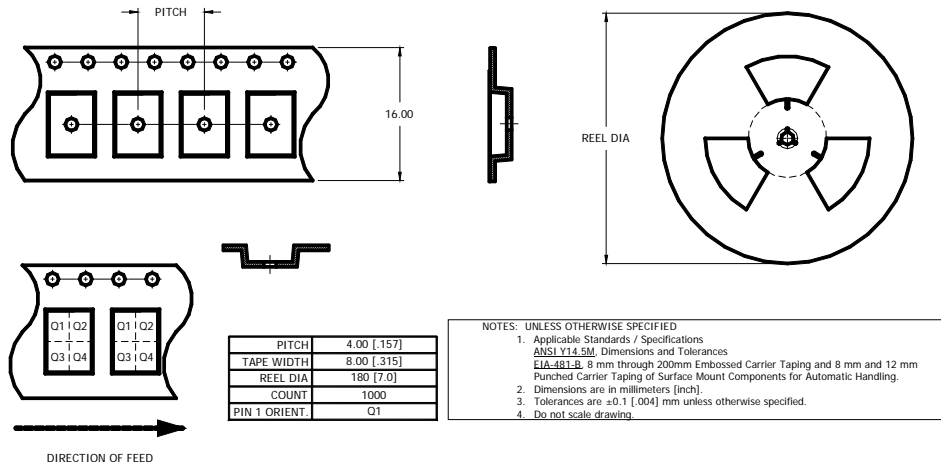

**MMD Monitor/Quartztek**  
 30400 Esperanza, Rancho Santa Margarita, CA, 92688  
 Phone: (949) 709-5075, Fax: (949) 709-3536, [www.mmdcomp.com](http://www.mmdcomp.com)  
 Sales@mmdcomp.com



Revision: 04/19/11 H