

A Series Crystal



- HC-49/U Thru-Hole Crystal
- RoHS Compliant Available
- Wide Frequency Range
- AT Cut
- Resistance Weld



Frequency Range	1.8432MHz to 200.000MHz
Frequency Tolerance / Stability	(See Part Number Guide for Options)
Operating Temperature Range	(See Part Number Guide for Options)
Storage Temperature	-55°C to +125°C
Aging	±5ppm / first year Max
Shunt Capacitance	7pF Max
Load Capacitance	20pF Standard (See Part Number Guide for Options)
Equivalent Series Resistance	See ESR Chart
Mode of Operation	Fundamental, 3 rd OT or 5 th OT
Drive Level	2mW Max

Environmental & Mechanical Detail

Shock	MIL-STD-883, Method 2002 Cond B
Solderability	MIL-STD-883, Method 2003
Solvent Resistance	MIL-STD-202, Method 215
Vibration	MIL-STD-883, Method 2007, Cond A
Gross Leak Test	MIL-STD-883, Method 1014, Cond C
Fine Leak Test	MIL-STD-883, Method 1014, Cond A2
MSL	Level 1 per IPC/JEDEC J-STD 20

Marking Detail

Line 1: MXX.XXX
XX.XXX = Frequency in MHz
Line 2: SYMCCL
S = Internal Code
YM = Date Code (Year/Month)
CC = Crystal Parameters Code
L = Denotes RoHS Compliant



MMD Monitor/Quartztek
 30400 Esperanza, Rancho Santa Margarita, CA, 92688
 Phone: (949) 709-5075, Fax: (949) 709-3536, www.mmdcomp.com
 Sales@mmdcomp.com

Revision:	1019/10 I
-----------	-----------

3rd Lead (Top of Can)

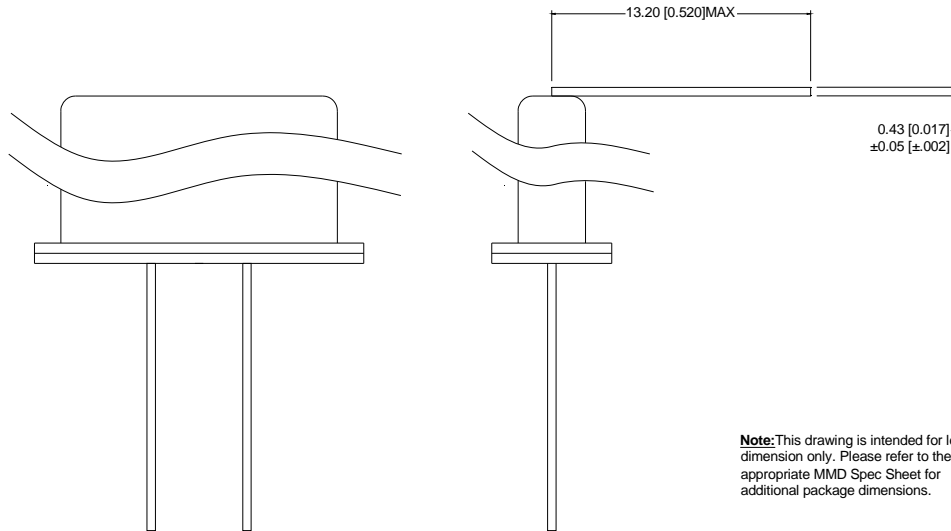

3 Lead Base

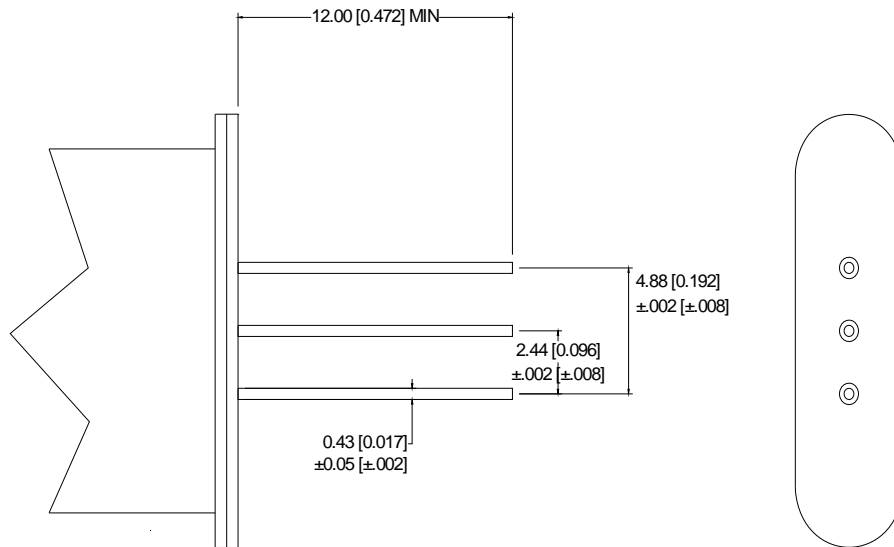

MMD Monitor/Quartztek
 30400 Esperanza, Rancho Santa Margarita, CA, 92688
 Phone: (949) 709-5075, Fax: (949) 709-3536, www.mmdcomp.com
 Sales@mmdcomp.com

Revision:	1019/10 I
-----------	-----------